

**THE SOLUTION TO YOUR
APPLICATION NEEDS**



**STRONG PARTNERS.
TOUGH TRUCKS.™**



XT SERIES

**INTERNAL COMBUSTION
COUNTERBALANCED FORKLIFT**

H1.5-3.5XT

1500 - 3500 KG

ABOUT HYSTER

Introducing the Hyster® H1.5-3.5XT counterbalanced forklift - the perfect combination of power, speed, low fuel consumption and clean performance.

Available with a range of standard and optional features, the H1.5-3.5XT model line-up is a powerful addition to maintain customer performance.

- Available in Dual Fuel, LPG and Diesel
- Load capacity from 1,500 – 3,500 kg
- Advanced control and operational functions; traction interlock, hydraulic interlock, side shift and fork positioning
- Wide variety of attachments
- Designed for optimum accessibility in servicing
- Aftermarket parts, service and support
- Ergonomic design for operator comfort
- Backed by an extensive dealer network

A global leader in the industry with manufacturing and technology centres in 12 locations around the world, Hyster provides a comprehensive range of warehousing equipment, industrial lift trucks and container handlers.

Hyster products are distributed and supported through an extensive network of exclusive dealers who provide local coverage through their sales and service locations across Asia-Pacific.

For more information about the Hyster H1.5-3.5XT counterbalanced truck or any Hyster product, talk to your local dealer.



FEATURES

1 HSM™ STABILITY SYSTEM >>

Hyster Stability Mechanism™ reduces truck lean in turns, improving lateral stability. The design enables the operator to travel over uneven surfaces with confidence.

2 REVERSE ASSIST GRIP* >>

The rear grab handle provides an excellent hand hold for reverse driving while giving easy access to the auxiliary horn button.

3 SYSTEM AND OPERATIONAL ALERTS >>

Audible and visible operational alerts including signal lights, rotating beacons and reverse buzzer.

4 ERGONOMIC SEAT >>

Operators can select their desired seating position with fore/aft and backrest recline adjustment. The weight adjustment knob on the full suspension seat ensures the most suitable suspension for the individual.

*Optional feature.



5 SIDE SHIFT* >>

Optional feature for adjusting and aligning loaded goods. It has a new structure to facilitate utmost productivity.

6 ERGONOMIC STEERING COLUMN >>

The infinitely adjustable tilt steer column allows operators to easily obtain a comfortable driving position. The 300mm diameter steering wheel is offset to the left for even greater driver comfort.

<< 10 ALL WEATHER STEEL CABIN*

Steel cabin protects the operator and provides comfort under harsh working conditions. Optional cabin fan is also available.

<< 9 EASY OPERATOR ACCESS

The low wide step, ample shoulder clearance and flow lined design of engine hood ensures easy operator accessibility upon unit ingress/egress.

<< 8 EXCLUSIVE VISTA™ MAST

The high strength design improves capacity retention at high lifts. Excellent visibility and rigidity for this class of truck.

<< 7 OPERATOR PRESENCE SYSTEM

Traction Interlock prevents travel and Hydraulic Interlock prevents use of hydraulic function when operator is not seated.

THE SOLUTION TO YOUR APPLICATION NEEDS

The Hyster® XT range represents a breakthrough in how lift trucks are designed, built and acquired. It starts with a commitment to quality and dependability, incorporating proven design processes and systems to deliver a class-leading product.

For the development of the product range, Hyster invested heavily in the best virtual, bench and field-testing equipment and processes in the industry and has ensured that only components of the highest quality are included in the truck. In addition, investments have been made in state-of-the-art manufacturing systems and processes to ensure unmatched Hyster quality.

As you would expect from Hyster, the trucks developed from this rigorous process boast the lowest cost of operation, maximum uptime, operator preferred ergonomics and unmatched performance.

Hyster XT - The Solution to your Application Needs



SETTING THE STANDARD FOR OPERATIONAL EFFICIENCY

Innovative Cooling System

The cooling system operates at lower temperatures. This offers significant improvement when it comes to cooling air flow, increasing component life and minimising the risk of overheating in heavy-duty applications. Optimised ducting and high volume tunnels allow Hyster XT lift trucks to run longer in a cooler state. Radiators are shockproof mounted for long life.

Hyster XT transmissions gear profiles are optimised to reduce operator noise in conjunction with isolated powertrain, minimising operator fatigue and improving comfort.

Integrated Dash Display

- Hour meter, date, time and alarm
- Travel speed/load weight indicator
- Coolant temperature level and fuel gauge indicator
- Password entry
- Error codes
- Visual warnings; battery charge, engine oil pressure, transmission fluid temperature, service reminder and seat belt.

HSM™ Stability System

The maintenance free HSM enhances lateral stability without compromising uneven surface travel, through reducing truck lean by limiting the articulation of the steer axle.

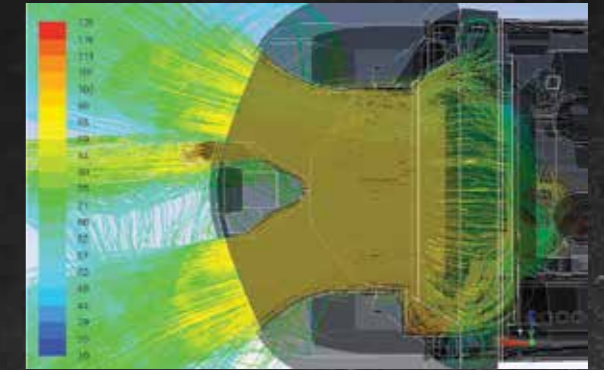

Maximised airflow for enhanced cooling.



Serpentine or square wave radiator – all models.



Dash display.



HSM.

ENHANCED PRODUCTIVITY

Productivity means moving more of your loads in less time with less cost. The development of the Hyster® XT range has focused on boosting performance to increase productivity and meet application requirements.

Take the hydraulic control module with shorter reach and throw levers requiring less effort to operate. Or the exceptional user visibility afforded for this class of truck by the Hyster Vista™ mast. In fact, wherever you look in the cabin, there's a feature designed to add to the comfort of the operator, from the low step height to the fully adjustable suspension seat, from the integrated dash display to the rear drive handle with horn.

Add other operator friendly features such as the low noise hydraulic pump and cabin together with the seamless forward and reverse directional changes, controlled through two optional methods, being the steer column mounted directional lever or the foot directional control monotrol and it's easy to see why drivers love the XT – and employers love the way it increases their productivity.

This increased productivity results in significant savings in materials handling costs through reduced operating expenses, labour costs and operator overtime and increased throughput.



1 SHIFT LEVERS >>

As standard, two levers operate the turn signal and forward/reverse operation. The right hand side turn signal includes a light switch (with auto canceller). Left hand lever enables a smooth directional change of forward/reverse.

2 HIGH VISIBILITY MAST >>

Enhanced operator visibility through the Vista™ Mast, means the operator can travel forward with greater confidence.



3 ERGONOMIC STEERING COLUMN >>

Offset steering column provides ideal left hand steering while the small diameter steering wheel reduces shoulder fatigue.

*Optional feature.



4 PARKING LEVER >>

This small stroke lever makes setting the brake easy. Lever includes a release button.



5 INCHING PEDALS* >>

Two types of inching pedals are available to increase the load speed. Pedals are on a suspended mount to free floor space.

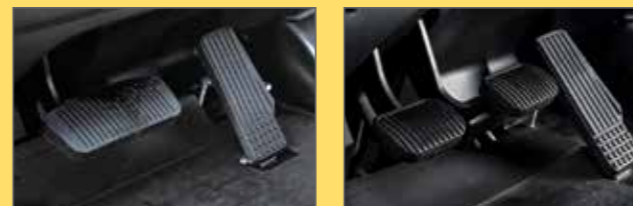

6 LED LIGHTS* >>

Brighter and longer lasting bulbs for side, reverse, rear, brake and direction indicators.



1 TRACTION INTERLOCK >>

- when operator is not present

The Traction Interlock function automatically reverts the truck to neutral when an operator is not seated. This prevents incidents caused by unintentional operations, such as pushing the accelerator pedal when the machine is not occupied.

2 HYDRAULIC INTERLOCK >>

- when operator is not seated

The Hydraulic Interlock function automatically disables the load levers when an operator is not seated. This prevents incidents caused by unintentional operations of the levers.



3 HIGH VISIBILITY MAST >>

Enhanced operator visibility through the Vista™ Mast, means the operator can travel forward with greater confidence.



4 OVERHEAD GUARD >>

The unique grid-style pattern improves visibility while protecting operators and strengthening the truck's structure.

5 ISOLATED POWERTRAIN >>

Helps to ensure that the operator remains comfortable and productive throughout the shift. The drivetrain is fully isolated through the use of elastomeric mounts for the engine and transmission.

OPERATORS PREFER HYSTER® XT LIFT TRUCKS

The Hyster XT offers a wide range of ergonomic and technologically advanced features, which have been adapted over years of operator feedback.

This has led to operators having a preference for Hyster XT lift trucks in order to optimise the efficiency of warehouse operations.



9



DRIVING COMFORT

Small steering wheel and adjustable steering column coupled with synchronous steering creates a comfortable and secure working environment.



8

EASY-TO-USE 3-POINT ENTRY DESIGN

Enables easy entry and exit and reduces muscle and joint stress. The truck features an open non-slip step with an optimised height and allows access from both sides.



7



EZXCHANGE™ BRACKET

Allowed for simple, quick exchanges of the LPG bottle – the bracket swings out and a gas-spring assisted cylinder lowers into a reclined and locked position.



6

HYDROSTATIC STEER AXLE

The elastomeric-mounted Hyster designed steer axle provides maximum durability and superior steering control for easy manoeuvring and low maintenance.

CUTTING DOWN DOWNTIME

The Hyster® XT Series doesn't just make it easier to carry out vital servicing tasks, it's a truck that has been designed to actually require less maintenance.

Hyster XT lift trucks offer best in class service access with a one-piece, rear-opening hood providing cowl-to-counterweight access. An easy to remove floor plate requires no tools and offers complete access to the powertrain.

Equipped with V-ECU the XT's truck functions are continuously monitored and keeps the operator fully informed of service needs. There's also state of the art on-board diagnostics on the advanced dash display to communicate error codes, enabling quick and accurate repairs.

What's more, when maintenance does need to take place, the XT is designed to make servicing as fast, convenient and simple as possible. It's extremely easy to perform engine compartment daily checks, check and replenish coolant levels and remove the radiator filler cap.

All backed up by the most dependable and most comprehensive parts availability in the industry, the Hyster XT gives you a greater degree of control over the efficiency and uptime of your operation than ever before.

1 EASY MAINTENANCE >>

One piece, easy opening hood allows for easy access to the engine. Full access is available by removing the rear panel.



2 INTEGRATED DASH DISPLAY >>

The integrated dash displays the most relevant information to the truck's current status. By actively showing service reminders and error codes, as well as warning indicators, it enables optimisation of lift truck diagnosis, reducing overall downtime.

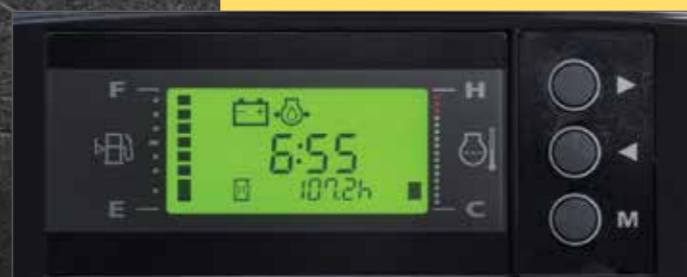

3 EXTENDED SERVICE INTERVALS >>

Periodic scheduled maintenance intervals have been extended to 500 hours for diesel and Petrol/LPG engines. Engine coolant and hydraulic oil change intervals have been extended to 4000 hours which help to reduce labour costs, as well as downtime.



TOTAL TRUCK RELIABILITY



With the XT Series from Hyster, total reliability comes built in. Put simply, every last component has been designed to provide long-lasting performance day in, day out, year after year.

Rugged durability is at the heart of the XT. Robust clutch packs, stronger gears and shafts, powertrain protection systems, enhanced monitoring – they all help to boost reliability, maximise uptime and keep your truck performing at its best. There's also a cooling system creating airflow through optimised ducting and high volume tunnels, helping to dramatically increase component life and minimise the risk of overheating in heavy duty applications.

From shock-proof mounted radiators to the check valves incorporated into the cushioned lift cylinders of the world-renowned Hyster® mast design, from the sealed connectors that enable the entire truck to be pressure washed to create leak-free joints, the XT delivers world-class reliability.

By utilising cutting edge technology and superior manufacturing facilities, Hyster engineers have delivered the highest serviceability ratings in the industry.

With the reputation for delivering world-class product reliability and to show our confidence in the XT series, it makes sense to back them with industry leading warranty.

That's why Hyster is offering the XT series with a standard 3 years/3,000 hours* manufacturer warranty and a lifetime chassis warranty.

* Comprises of 1 year/2000 hours on complete truck and 3 years/3000 hours on powertrain.

LOW COST OF OWNERSHIP BUILT IN

The Hyster XT has been designed to help you lower your ownership costs in all types of applications, through offering a wide range of engine options to suit the application need.

The XT range is not only fuel efficient but has a longer tyre life and reduced brake wear contributing to reduced service time.

For example, the available Load Sensing Hydraulics system delivers increased operational efficiency, as the engine only supplies power to the hydraulic pumps when required.

This delivers increased responsiveness and acceleration, which helps to maximise productivity and lower fuel consumption, reducing overall operating costs.

This, combined with a 30% decrease in downtime, makes the Hyster XT series an exceptionally smart choice.



MANAGE COST, OPTIMISE PRODUCTIVITY AND PROTECT YOUR ASSETS

Hyster Tracker System

Take your fleet operation to the next level with wireless asset management from Hyster. Hyster Tracker System provides true wireless fleet management, can drive fleet efficiency, improves operator performance, reduces your carbon footprint and lowers your overall material handling costs.

- Manage your total cost of operation
- Ensure maximum productivity from your lift truck investment
- Monitor operator behavior, promote safety
- Convenient web-based access, and your choice of three levels of management

Data is great, but your Hyster Dealer will make it work for you

Hyster Tracker System is a great addition to your management toolkit. But when you partner with your Hyster Dealer, you get the best of both worlds – great fleet data plus the unmatched knowledge and experience that can help you get the most out of every truck in your fleet.

STANDARD FEATURES AND OPTIONS

STANDARD FEATURES

- 2 Stage LFL mast
- Operator presence
 - Hydraulic interlock
 - Travel interlock
- Cowl mounted levers
- Trunnion mount mast
- Full halogen light kit including turn indicators
- Head light guards
- Rotating LED beacon
- Swing down LPG bracket
- Small diameter steering wheel
- Rubber floor mat
- Entry assist grip
- Electric directional shift lever
- Neutral start
- Reverse alarm
- Separate inch/brake pedal
- Comprehensive dash display
- Single element air cleaner
- Rubber mount rear axle
- Wide mast with wide field vision

OPTIONAL FEATURES

- Engine options – LPG, Diesel, Dual Fuel
- Mast options
 - 2 Stage LFL mast – 3000mm to 5000mm lift
 - 2 Stage FFL mast – 3300mm to 4100mm lift
 - 3 Stage FFL mast – 4000mm to 6000mm lift
- Integral side shift carriage
- Fork lengths – 920mm to 2120mm
- Tyre options – pneumatic, solid, non-marking
- Control valve options
- Front screens
- Rain covers
- Cabs
- Pre-cleaner for air filter
- LED lighting
- Speed meter
- Load weight meter
- Special paint
- Reverse assist grip with horn button
- Hyster Tracker System

DIMENSIONS

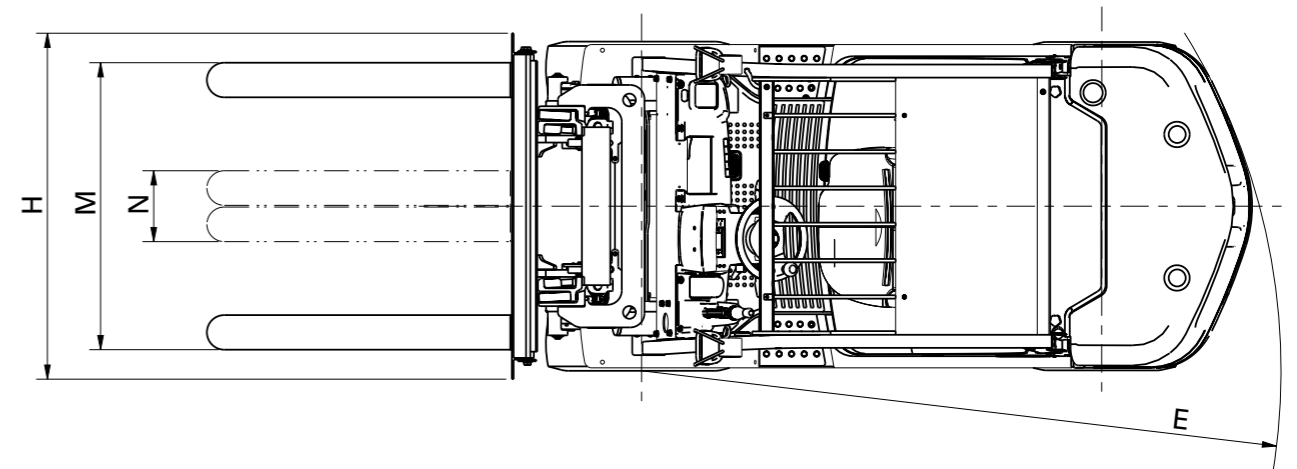
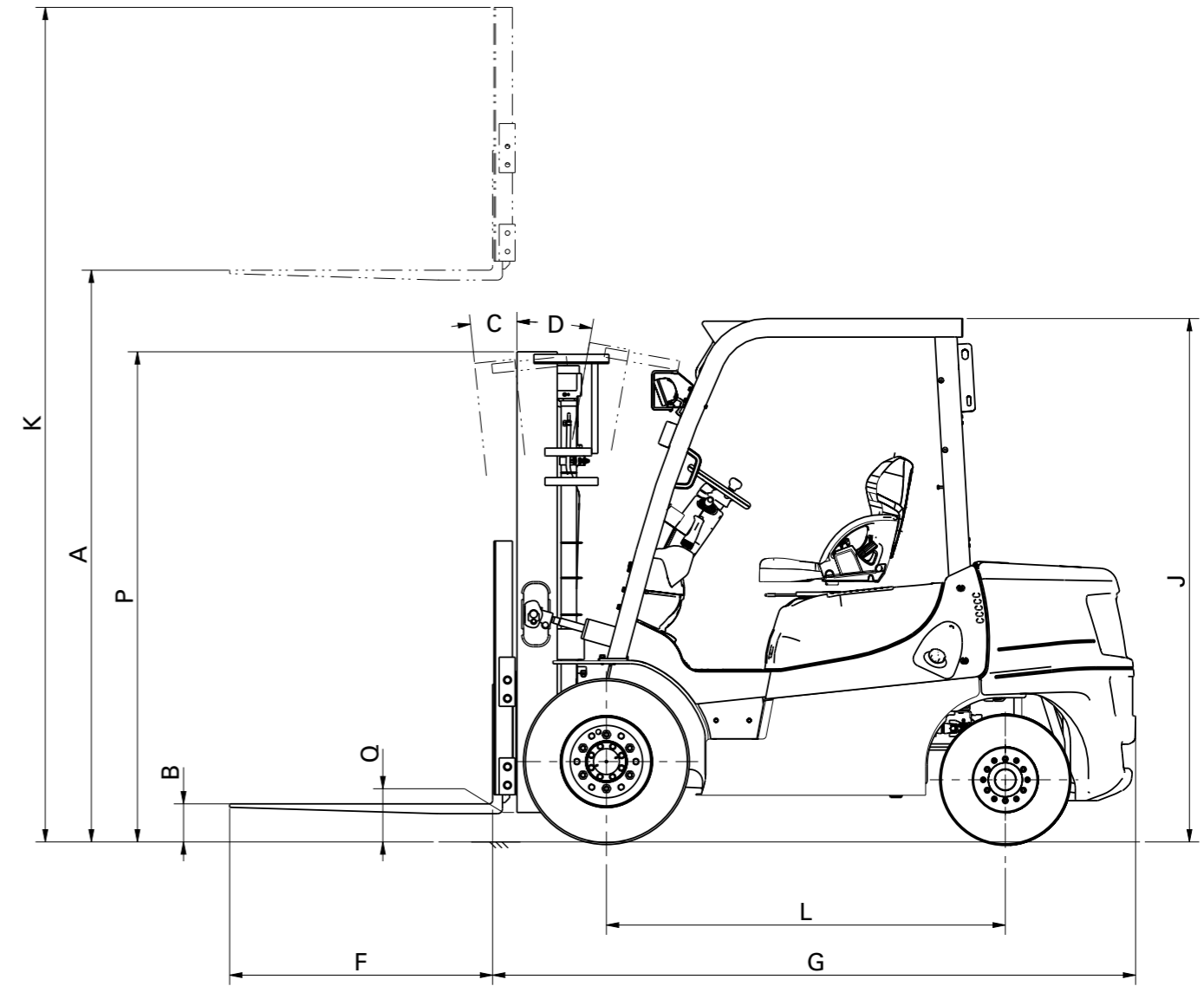

SPECIFICATIONS

SPECIFICATION	MANUFACTURER		DIESEL									
	HYSTER		HYSTER									
	Model		H1.5XT	H1.8XT	H2.0XTS	H2.0XT	H2.5XT	H3.0XT	H3.5XT			
1	Capacity	kg	1500	1750	2000	2000	2500	3000	3500			
2	Load centre	mm	500	500	500	500	500	500	500			
3	Tyres		Pneumatic	Pneumatic	Pneumatic	Pneumatic	Pneumatic	Pneumatic	Pneumatic			
4	Wheels	No. front/rear (x=Drive)	2X/2	2X/2	2X/2	2X/2	2X/2	2X/2	2X/2			
DIMENSIONS	9	Lift height	mm	A	3000	3000	3000	3000	3000	3000		
	10	Standard free lift	mm	B	145	145	150	155	155	160		
	12	Fork carriage	Carriage width/TA class	H	1020/2	1020/2	1020/2	1020/2	1020/2	1070/3		
	13	Fork	Thickness/width/length	mm	35/100/920	35/100/920	40/122/920	40/122/920	40/122/1070	45/122/1070	50/150/1070	
	14	Tilt of mast	Forward/backward	deg	C/D	6/10	6/10	6/10	6/10	6/10	6/10	
		Fork spread	Max/min	mm	M/N	915/205	915/205	910/250	1010/250	1010/250	1060/250	1065/305
		Overall length	Length to tip of forks	mm	F+G	3200	3240	3275	3470	3685	3835	3905
	15	Truck length	Length to face of forks	mm	G	2280	2320	2355	2550	2615	2765	2835
	16	Overall width	Tyre/frame	mm		1070/1070	1135/1070	1135/1070	1160/1140	1160/1140	1235/1140	1235/1140
	16A	Overall width	Tyre/frame (Dual tread)	mm		1190/1070	1190/1070	1190/1070	1590/1140	1590/1140	1590/1140	1490/1140
	17	Height	Height with lowered mast	mm	P	1995	1995	1995	1995	1995	2060	2140
	18	Height	Height with extended mast	mm	K	4105	4105	4105	4120	4120	4125	4125
	19	Height	Height of overhead guard canopy	mm	J	2060	2060	2060	2130	2130	2150	2150
	20	Seat height		mm		920	920	920	990	990	1010	1010
	21	Turning radius		mm	E	1960	1995	2030	2185	2245	2365	2415
22	Load length 'X'	Centre of front wheel to face of forks	mm		410	410	415	465	465	490	505	
23	Right angle stacking aisle width	Add load length and clearance	mm		2165	2205	2240	2470	2530	2650	2715	
PERFORMANCE	24	Travel speed	Laden/unladen with standard engine	km/h	17/18.0	17/18.5	17/18.5	17.5/19	17.5/19	17.5/18.5	17.5/18	
		Laden/unladen with optional engine	km/h	17/18.0	17/18.5	17/18.5	17.5/19	17.5/19	17.5/18.5	17.5/18		
	25	Lifting speed	Laden/unladen with standard engine	mm/s	675/710	665/710	655/710	620/670	610/670	560/570	475/490	
		Laden/unladen with optional engine	mm/s	NA	NA	NA	675/690	675/690	NA	NA		
26	Lowering speed	Laden/unladen	mm/s	495/520	495/520	495/520	495/520	495/520	495/520	495/520		
	Drawbar pull	Laden/unladen @ 1.5km/h with standard engine	N	17500	17400	17500	16700	16700	22300	20400		
		Laden/unladen @ 1.5km/h with optional engine	N	NA	NA	NA	21800	21900	NA	NA		
	Gradeability	Laden/unladen @ 1.5km/h with standard engine	%	36/24	32/22	29/20	26/26	22/23	27/22	21/19		
		Laden/unladen @ 1.5km/h with optional engine	%	NA	NA	NA	35/26	30/23	NA	NA		
WEIGHT	32	Unladen weight	Standard tread	kg	2700	2910	3130	3440	3770	4280	4770	
	33	Axle loads	Laden front/rear	kg	3630/550	4020/640	4430/700	4760/680	5500/780	6390/890	7250/1020	
	34		Unladen front/rear	kg	1120/1420	1140/1770	1130/2000	1580/1860	1510/2260	1650/2630	1700/3070	
CHASSIS AND WHEELS	36	Tyre sizes	Front (standard tread)		6.00-9-10PR	21x8-9-14PR	21x8-9-14PR	7.00-12-12PR	7.00-12-12PR	28x9-15-12PR	28x9-15 SOLID	
			Front (dual tread)		21x8-9-14PR	21x8-9-14PR	21x8-9-14PR	7.00-12-12PR	7.00-12-12PR	7.00-12-12PR	6.00-15 SOLID	
			Rear		5.00-8-8PR	18x7-8-10PR	18x7-8-10PR	6.00-9-10PR	6.00-9-10PR	6.50-10-10PR	6.50-10 SOLID	
	38	Wheelbase		mm	L	1410	1410	1410	1625	1700	1700	
	39	Tread	Standard tread: front/rear	mm	915/905	950/930	950/930	970/1000	970/1000	1010/1000	1010/1000	
	39A		Dual tread: front/rear	mm	1000/905	1000/930	1000/930	1405/1000	1405/1000	1405/1000	1330/1000	
	40	Ground clearance	At lowest point	mm	Q	110	110	110	120	120	140	140
	41		Centre of wheel base	mm		120	120	120	190	190	210	210
	42	Service brake	Mechanical/hydraulic/electric/pneumatic			Hydraulic	Hydraulic	Hydraulic	Hydraulic	Hydraulic	Hydraulic	Hydraulic
	43	Parking brake	Foot/hand/dead man break			Hand	Hand	Hand	Hand	Hand	Hand	Hand
DRIVE	49	Standard engine	Manufacturer/model		YANMAR 4TNE92	YANMAR 4TNE92	YANMAR 4TNE92	YANMAR 4TNE92	YANMAR 4TNE92	YANMAR 4TNE98	YANMAR 4TNE98	
	50		Permanent output	kW	29	29	29	29	29	43	43	
	51		At revs	rpm	2050	2050	2050	2050	2050	2300	2300	
			Rated torque	Nm/rpm	150/1400	150/1400	150/1400	150/1400	150/1400	198/1600	198/1600	
	52	No. of cylinder/cubic capacity	cm³	4/2659	4/2659	4/2659	4/2659	4/2659	4/3319	4/3319		
	49	Optional engine	Manufacturer/model		NA	NA	NA	YANMAR 4TNE98	YANMAR 4TNE98	NA	NA	
	50		Permanent output	kW	NA	NA	NA	43	43	NA	NA	
	51		At revs	rpm	NA	NA	NA	2300	2300	NA	NA	
			Rated torque	Nm/rpm	NA	NA	NA	198/1600	198/1600	NA	NA	
	52		No. of cylinder/cubic capacity	cm³	NA	NA	NA	4/3319	4/3319	NA	NA	
	Fuel tank		Ltr	52	52	52	69	69	69	69		
53	Fuel consumption	Ltr/h	☞	☞	☞	☞	☞	☞	☞			
55	Transmission	With ICE drive			AT	AT	AT	AT	AT	AT		
OTHERS	57	Working pressure	For attachments	Mpa	18.1	18.1	18.1	18.1	18.1	18.1	15.7	
	58	Noise level - standard engine	BITA/ISO Leq 3dB Doubling	dB(A)	☞	☞	☞	☞	☞	☞	☞	

SPECIFICATIONS

SPECIFICATION	MANUFACTURER		DIESEL - Tier 4				
	HYSTER		HYSTER				
	Model		H2.0XT	H2.5XT	H3.0XT	H3.5XT	
1	Capacity	kg	2000	2500	3000	3500	
2	Load centre	mm	500	500	500	500	
3	Tyres		Pneumatic	Pneumatic	Pneumatic	Pneumatic	
4	Wheels	No. front/rear (x=Drive)	2X/2	2X/2	2X/2	2X/2	
DIMENSIONS	9	Lift height	mm	A	3000	3000	3000
	10	Standard free lift	mm	B	155	155	160
	12	Fork carriage	Carriage width/TA class	H	1020/2	1020/2	1070/3
	13	Fork	Thickness/width/length	mm	40/122/920	40/122/1070	45/122/1070
	14	Tilt of mast	Forward/backward	deg	C/D	6/10	6/10
		Fork spread	Max/min	mm	M/N	1010/250	1010/250
		Overall length	Length to tip of forks	mm	F+G	3470	3685
	15	Truck length	Length to face of forks	mm	G	2550	2615
	16	Overall width	Tyre/frame	mm		1160/1140	1160/1140
	16A	Overall width	Tyre/frame (Dual tread)	mm		1590/1140	1590/1140
	17	Height	Height with lowered mast	mm	P	1995	1995
	18	Height	Height with extended mast	mm	K	4120	4120
	19	Height	Height of overhead guard canopy	mm	J	2130	2130
	20	Seat height		mm		990	990
	21	Turning radius		mm	E	2185	2245
22	Load length 'X'	Centre of front wheel to face of forks	mm		465	465	
23	Right angle stacking aisle width	Add load length and clearance	mm		2470	2530	
PERFORMANCE	24	Travel speed	Laden/unladen with standard engine	km/h	18/19.5	18/19.5	17.5/18.5
		Laden/unladen with optional engine	km/h	NA	NA	NA	
	25	Lifting speed	Laden/unladen with standard engine	mm/s	675/700	675/700	560/575
		Laden/unladen with optional engine	mm/s	NA	NA	NA	
26	Lowering speed	Laden/unladen	mm/s	495/520	495/520	495/520	
	Drawbar pull	Laden/unladen @ 1.5km/h with standard engine	N	21600	21700	22200	
		Laden/unladen @ 1.5km/h with optional engine	N	NA	NA	NA	
	Gradeability	Laden/unladen @ 1.5km/h with standard engine	%	35/25	30/22	26/21	
		Laden/unladen @ 1.5km/h with optional engine	%	NA	NA	NA	
WEIGHT	32	Unladen weight	Standard tread	kg	3650	3790	4290
	33	Axle loads	Laden front/rear	kg	5080/580	5550/740	6470/840
	34		Unladen front/rear	kg	1870/1780	1570/2220	1720/2580
CHASSIS AND WHEELS	36	Tyre sizes	Front (standard tread)		7.00-12-12PR	7.00-12-12PR	28x9-15-12PR
			Front (dual tread)		7.00-12-12PR	7.00-12-12PR	7.00-12-12PR
			Rear		6.00-9-10PR	6.00-9-10PR	6.50-10 SOLID
	38	Wheelbase		mm	L	1625	1625
	39	Tread	Standard tread: front/rear	mm	970/1000	970/1000	1010/1000
	39A		Dual tread: front/rear	mm	1405/1000	1405/1000	1405/1000
	40	Ground clearance	At lowest point	mm	Q	120	120
	41		Centre of wheel base	mm		190	210
	42	Service brake	Mechanical/hydraulic/electric/pneumatic			Hydraulic	Hydraulic
	43	Parking brake	Foot/hand/dead man break			Hand	Hand
DRIVE	49	Standard engine	Manufacturer/model		KUBOTA V2403	KUBOTA V2403	KUBOTA V2403
	50		Permanent output	kW	43	43	43
	51		At revs	rpm	2400	2400	2400
			Rated torque	Nm/rpm	199/1500	199/1500	199/1500
	52	No. of cylinder/cubic capacity	cm³	4/2434	4/2434	4/2434	
	49	Optional engine	Manufacturer/model		NA	NA	NA
	50		Permanent output	kW	NA	NA	NA
	51		At revs	rpm	NA	NA	NA
			Rated torque	Nm/rpm	NA	NA	NA
	52		No. of cylinder/cubic capacity	cm³	NA	NA	NA
	Fuel tank		Ltr	69	69	69	
53	Fuel consumption	Ltr/h	☞	☞	☞		
55	Transmission	With ICE drive			AT	AT	
OTHERS	57	Working pressure	For attachments	Mpa	18.1	18.1	18.1
	58	Noise level - standard engine	BITA/ISO Leq 3dB Doubling	dB(A)	☞	☞	☞

MAST SPECIFICATIONS

H1.5XT				
2-Stage Limited Free Lift Vista Mast				
Maximum Fork Height mm	BackTilt deg	Overall Lowered Height mm	Overall Extended Height mm	Free Lift mm
3035	10	1995	4105	145
3335	10	2145	4405	145
3535	10	2245	4605	145
3735	10	2345	4805	145
4035	6	2595	5105	145
4335	6	2745	5405	145
4535	6	2845	5605	145
4835	6	2995	5905	145
5035	6	3095	6105	145
2-Stage Full Free Lift Vista Mast				
3025	10	1995	4095	925
3325	10	2145	4395	1075
3525	10	2245	4595	1175
3725	10	2345	4795	1275
4125	6	2595	5195	1525
3-Stage Full Free Lift Vista Mast				
4025	6	1895	5095	825
4375	6	1995	5445	925
4525	6	2045	5595	975
4825	6	2145	5895	1075
5125	6	2245	6195	1175
5425	6	2345	6495	1275
6025	6	2595	7095	1525

H1.8XT				
2-Stage Limited Free Lift Vista Mast				
Maximum Fork Height mm	BackTilt deg	Overall Lowered Height mm	Overall Extended Height mm	Free Lift mm
3035	10	1995	4105	145
3335	10	2145	4405	145
3535	10	2245	4605	145
3735	10	2345	4805	145
4035	6	2595	5105	145
4335	6	2745	5405	145
4535	6	2845	5605	145
4835	6	2995	5905	145
5035	6	3095	6105	145
2-Stage Full Free Lift Vista Mast				
3025	10	1995	4095	925
3325	10	2145	4395	1075
3525	10	2245	4595	1175
3725	10	2345	4795	1275
4125	6	2595	5195	1525
3-Stage Full Free Lift Vista Mast				
4025	6	1895	5095	825
4375	6	1995	5445	925
4525	6	2045	5595	975
4825	6	2145	5895	1075
5125	6	2245	6195	1175
5425	6	2345	6495	1275
6025	6	2595	7095	1525

H2.0XTS				
2-Stage Limited Free Lift Vista Mast				
Maximum Fork Height mm	BackTilt deg	Overall Lowered Height mm	Overall Extended Height mm	Free Lift mm
3040	10	1995	4105	150
3340	10	2145	4405	150
3540	10	2245	4605	150
3740	10	2345	4805	150
4040	6	2595	5105	150
4340	6	2745	5405	150
4540	6	2845	5605	150
4840	6	2995	5905	150
5040	6	3095	6105	150
2-Stage Full Free Lift Vista Mast				
3030	10	1995	4095	930
3330	10	2145	4395	1080
3530	10	2245	4595	1180
3730	10	2345	4795	1280
4130	6	2595	5195	1530
3-Stage Full Free Lift Vista Mast				
4030	6	1895	5095	830
4380	6	1995	5445	930
4530	6	2045	5595	980
4830	6	2145	5895	1080
5130	6	2245	6195	1180
5430	6	2345	6495	1280
6030	6	2595	7095	1530

H2.0-2.5XT				
2-Stage Limited Free Lift Vista Mast				
Maximum Fork Height mm	BackTilt deg	Overall Lowered Height mm	Overall Extended Height mm	Free Lift mm
3050	10	1995	4120	155
3350	10	2170	4420	155
3550	10	2270	4620	155
3750	10	2420	4820	155
4050	10	2620	5120	155
4350	6	2770	5420	155
4550	6	2870	5620	155
4850	6	3020	5920	155
5050	6	3120	6120	155
2-Stage Full Free Lift Vista Mast				
3000	10	1995	4070	925
3390	10	2270	4460	1200
3590	10	2370	4660	1300
3840	10	2520	4910	1450
4190	6	2720	5260	1650
3-Stage Full Free Lift Vista Mast				
4135	6	1970	5210	900
4345	6	2040	5420	970
4585	6	2120	5660	1050
4840	6	2205	5910	1135
5035	6	2270	6110	1200
5335	6	2370	6410	1300
5535	6	2470	6610	1400
5685	6	2520	6760	1450
6035	6	2720	7110	1650

MAST SPECIFICATIONS

H3.0XT				
2-Stage Limited Free Lift Vista Mast				
Maximum Fork Height mm	BackTilt deg	Overall Lowered Height mm	Overall Extended Height mm	Free Lift mm
3055	10	2060	4125	160
3355	10	2210	4425	160
3555	10	2310	4625	160
3755	10	2440	4825	160
4055	10	2640	5125	160
4355	6	2790	5425	160
4555	6	2890	5625	160
4855	6	3040	5925	160
5055	6	3140	6125	160
2-Stage Full Free Lift Vista Mast				
3080	10	2140	4150	1070
3380	10	2290	4450	1220
3580	10	2390	4650	1320
3830	10	2540	4900	1470
4180	6	2740	5250	1670
3-Stage Full Free Lift Vista Mast				
4125	6	1990	5195	920
4335	6	2060	5405	990
4575	6	2140	5645	1070
4705	6	2225	5775	1155
5025	6	2390	6095	1320
5325	6	2540	6395	1470
5525	6	2640	6595	1570
5725	6	2740	6795	1670
6025	6	2890	7095	1820

H3.5XT				
2-Stage Limited Free Lift Vista Mast				
Maximum Fork Height mm	BackTilt deg	Overall Lowered Height mm	Overall Extended Height mm	Free Lift mm
3060	10	2140	4080	165
3360	10	2290	4380	165
3560	10	2390	4580	165
3760	10	2490	4780	165
4060	10	2690	5080	165
4360	6	2840	5380	165
4560	6	2940	5580	165
4860	6	3090	5880	165
5060	6	3190	6080	165
2-Stage Full Free Lift Vista Mast				
3085	10	2190	4105	1120
3385	10	2340	4405	1270
3585	10	2440	4605	1370
3835	10	2590	4855	1520
4185	6	2790	5205	1720
3-Stage Full Free Lift Vista Mast				
4130	6	2040	5150	970
4340	6	2110	5360	1040
4580	6	2190	5600	1120
4830	6	2340	5850	1270
5030	6	2440	6050	1370
5330	6	2590	6350	1520
5530	6	2690	6550	1620
5730	6	2790	6750	1720
6030	6	2940	7050	1870

Note: Overall extended height and free lift assume standard load back rest height of 1070mm.

CAPACITY CHARTS

STANDARD CARRIAGE - H1.5-1.8XT, H2.0XTS

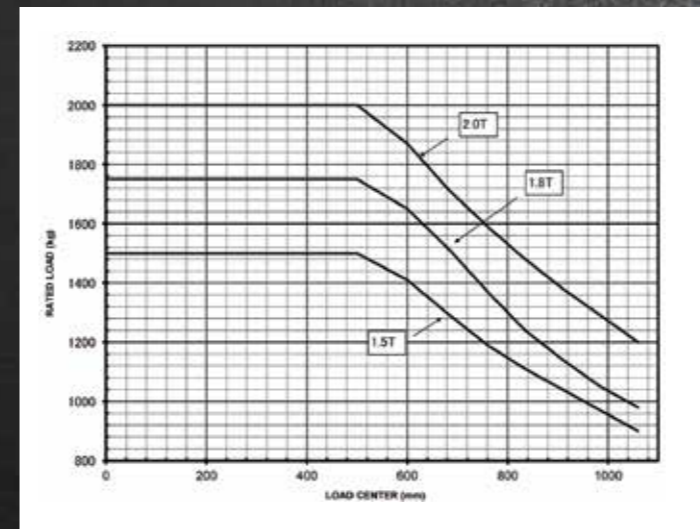

STANDARD CARRIAGE - H2.0-3.5XT

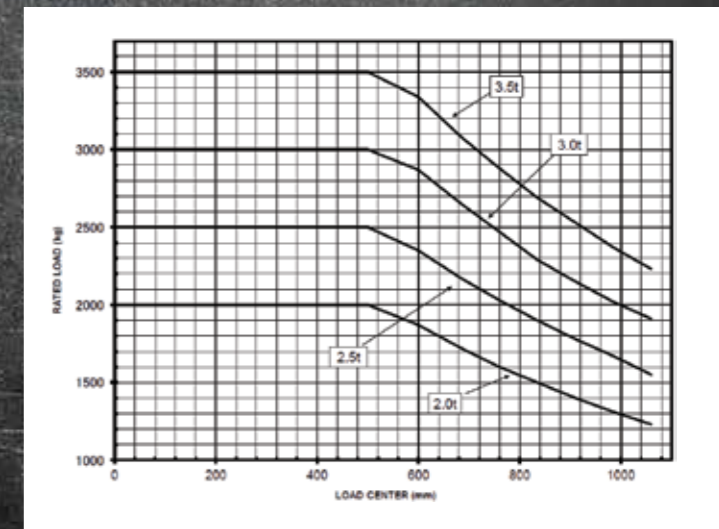

HYSTER® DEALERS



Contact your nearest Hyster® Dealership
by visiting www.hyster.com.au

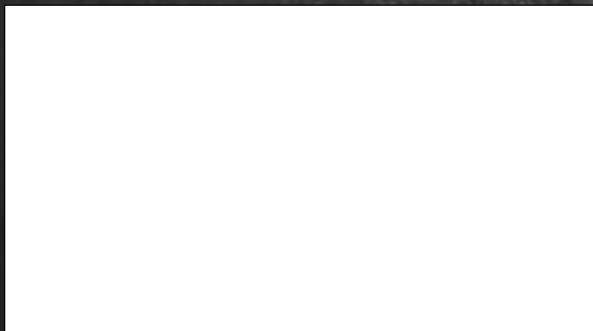

HYSTER PACIFIC

1 Bullecourt Avenue, Milperra NSW, Australia 2214
Tel: +61 (2) 9795 3800 Fax: +61 (2) 9792 8484
hyster.com/pacific/en-au

HYSTER ASIA

16 Tuas Avenue 20, Singapore 638827
Tel: +65 6863 3387 Fax: +65 6863 3349
hyster.com/asia/en-sg



/Hysterasiapacific



HysterJAPIC



Hyster Asia-Pacific